

## INDOOR BOILER WITH USED OIL BURNER FOR COMMERCIAL/INDUSTRIAL USE



**Model RAB used oil boilers meet EPA requirements for disposal of used oil.**

NOTE: Used oil boilers are not approved for sale in the state of California.

### Description

Reznor® Model RAB Series Used Oil Boilers are available in two sizes with BTUH inputs of 350,000 and 500,000. The boilers are equipped with burners that are designed to burn used oil but will also burn No. 2 fuel oil. The used oil must be no heavier than 50 weight and not lighter than No. 2 fuel oil.

Model RAB used oil boilers include the same style burner, oil preheater, and positive displacement pump as other Reznor used oil heaters. The air atomizing burner mounted on the boiler door provides excellent flame retention. Air for atomization of the oil is provided by a piston-type compressor mounted on a shelf on the side of the boiler. The oil preheating system (U.S. Patent No. 5,080,579) heats the oil, maintaining it at a temperature required for atomization but preventing nozzle after-drip. The burner has electric spark ignition and an electronic cad-cell flame safety system with manual reset. A 115 volt, 60 Hz power supply is required. The remote fuel pump mounted on or near the oil supply tank is part of a unique positive pressure supply system providing a precisely metered flow of oil to the burner. This positive displacement pump produces a stable flame under a wide range of operating parameters. The supply tank must be no closer than 5 ft and no farther than 50 ft from the boiler. It is recommended that used oil be at a temperature of 50°F or higher when it enters the pump. At a temperature below 50°F, oil becomes more viscous and difficult to pump and may cause the burner to fire at a reduced rate and become erratic resulting in nuisance shutdowns. A fuel line filter, with a cleanable strainer and vacuum gauge, and

a foot valve are provided for installation in the field-supplied suction line that runs from the supply tank to the fuel pump.

The boiler is made of GL-180M silicone injected, gray cast iron giving it excellent corrosion resistance, flexibility, and high thermal conductivity. The double wall sectional construction allows for a high efficiency three pass heat exchanger. Flue ways are sealed gas-tight with tongue and groove designed sections and elastic high temperature sealing rope. The unique water flow pattern eliminates thermal shock by using supply water to pre-heat the return water before it enters the main heat exchanger. Under normal conditions, there is no minimum return water temperature and no minimum flow requirements. A minimum supply temperature of 122°F must be maintained during burner operation. (NOTE: If the application could include a return with the temperature of ice water, maintain 158°F in the boiler.) Internal water circulation and injection combined with deflection plates ensure condensate-free boiler operation under no-flow conditions.

Model RAB used oil boilers meet EPA requirements for disposal of used oil.

### Standard Features

- Remote oil pumping system provides a metered flow of fuel
- Oil preheating system (U.S. Patent No. 5,080,579)
- Air atomizing burner
- Electric spark ignition with electronic cad-cell flame safety system
- Piston air compressor with replaceable filter
- Terminal block wiring
- Built-in disconnect switches (pump and burner)
- Observation and over-fire draft sampling ports
- Oil supply line filter system with cleanable strainer and dirty filter indicator gauge
- Operation hour meter
- Barometric draft regulator
- Draft inducer
- Low water shut-off
- Relief valve
- Pressure gauge
- Flexible fuel line for service to the burner and nozzle (without disconnecting the fuel line)
- Three-pass design boiler of silicone injected cast iron with enamel jacket and 3" wraparound thermal insulation
- Large combustion chamber with Pyroflex® liner
- Full-size, hinged door for service access has a permanent gasket that provides a positive seal
- Water supply and return connections at rear of boiler

### Technical Data

Model RAB	350	500
Burner BTUH Input	350,000	500,000
Burner BTUH Thermal Output	290,500	415,000
Fuel Flow Rate or Nozzle Input (GPH)	2.5	3.57
Flue Collar (inches) - transition required to 8" vent pipe	7	7
Flue Pipe and Vent Cap (inches)	8	8
Voltage-Full Load Amps (without water circulating pump)	115V-17	115V-19
Maximum Boiler Temperature (°F)	240	240
Maximum Operating Pressure (psi)	58	58
Water Content (gallons)	37.8	52.6
Water Supply and Return Connections (inches)	3	3
Approximate Net Wt. (lbs.)	1247	1635
Approximate Shipping Wt (lbs.)	1450	1850

### Accessories - Field Installed

- Vent cap
- 250 gallon workbench oil tank (Model OT250)

**Dimensions (inches and mm)**

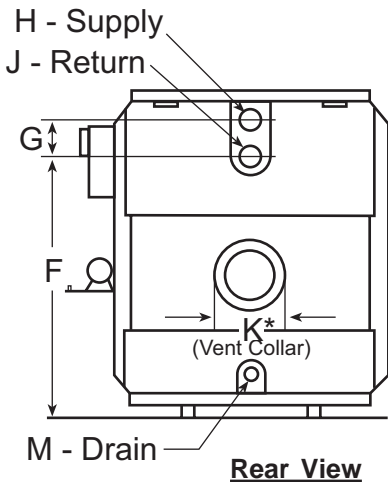
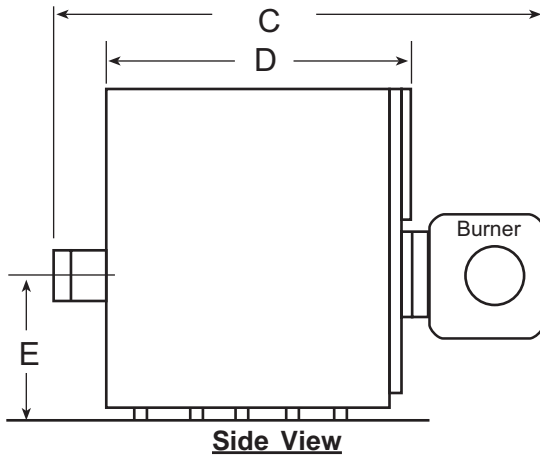
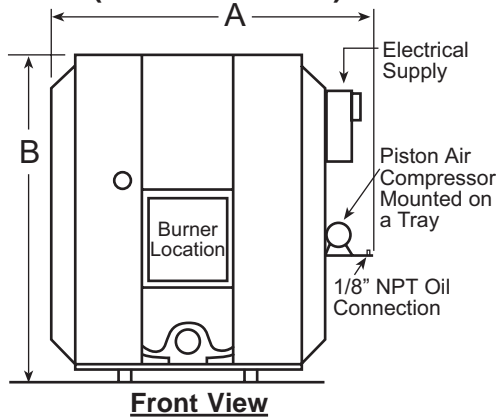

\*K is the diameter of the flue collar on the boiler. Transition is required to an 8" vent pipe that is terminated with an 8" vent cap.

**Dimensions - inches (mm)**

Size	350	500
A	40-1/4 (1029)	40-1/4 (1029)
B	40-3/4 (1035)	40-3/4 (1035)
C	56-1/4 (1429)	68-3/4 (1746)
D	44-1/4 (1124)	56-3/4 (1441)
E	17-3/4 (451)	17-3/4 (451)
F	32-1/4 (819)	32-1/4 (819)
G	4-3/4 (121)	4-3/4 (121)
H (supply)	3 (77)	3 (77)
J (return)	3 (77)	3 (77)
K (flue collar)*	7 (178)	7 (178)
M (drain)	3/4 (19)	3/4 (19)

**Minimum Clearances - inches (mm)**

Front	Recommended for service access - D + 40" (1,016mm). Absolute minimum - 36" (914mm).
Side (with electrical box)	Recommended for service access - 24" (610 mm). Absolute minimum - 15" (38mm).
Side (opposite electrical box)	12" (305mm)
Rear	Recommended for service access - 41" (1,041mm). Absolute minimum - 36" (914mm).
Flue Pipe	18" (457mm)

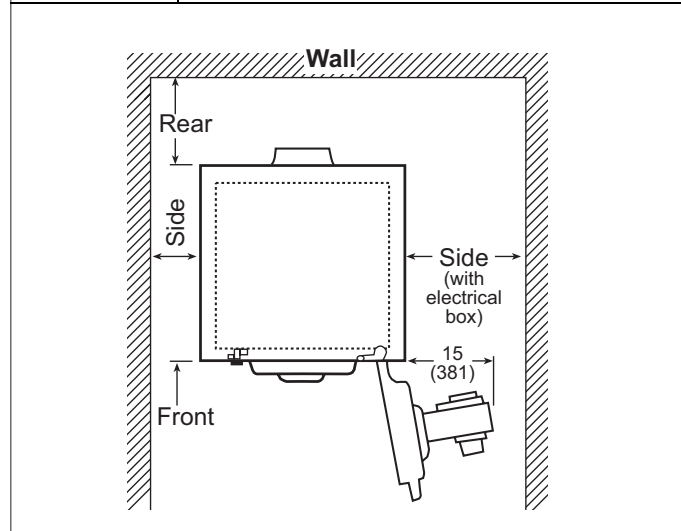

**Installation Notes:**

A draft inducer and a barometric draft regulator are factory-supplied with all boilers. Both **must** be included in the installation. An 18" (457mm) clearance is required from the top of the draft regulator to a combustible ceiling.

**Reference:** For information about Reznor® Model OT-250 Workbench Fuel Tank, contact your distributor or check the Website ([www.ReznorHeaters.com](http://www.ReznorHeaters.com)).

**CAUTION:** These boilers are designed to provide economical disposal of used oil. Due to the nature of the fuel being burned, this unit should not be depended on as an only source of building heat. Any water or foreign material in the oil may cause the burner to shutdown. A secondary source of heat should always be provided to a building. This will prevent any building damage if the used oil boiler is to become inoperative during subfreezing weather.

(800) 695-1901 Press 2; [www.ReznorHeaters.com](http://www.ReznorHeaters.com)

©2006 Thomas & Betts Corporation. All rights reserved. Printed in the U.S.A.

MANUFACTURER OF GAS, OIL, ELECTRIC HEATING AND VENTILATING SYSTEMS

Trademark Notes: Reznor® is registered in the United States and other countries. All other trademarks are the property of their respective organizations.

8/06 Form S-RAB (Version B.1)

**Thomas & Betts**